

ES-Key Systems

MULTIPLEXING SOLUTIONS FOR YOUR VEHICLE



ES-Key System

J1939 is the real-time CAN solution for heavy duty vehicle applications.

The ES-Key® Multiplexing System is a highly scalable and extremely adaptable system, making it perfect for a wide variety of applications. The ES-Key System was designed to meet the extreme demands of the fire service industry so quality is second to none. Class1 has helped customers migrate the ES-Key system into nearly every mobile equipment application imaginable. This vast experience has expanded our off the shelf product line to the most extensive in the industry. We have the ability to respond to the demands of the custom vehicle industry with proprietary and custom components and interfaces. The decision to utilize the ES-Key System ensures vehicle manufacturers the most advanced and highest quality multiplexing system in their industries.



The 1Touch switch panel is a fully customizable switch solution for use with the ES-Key distributed multiplex network. The 1Touch switch allows control and indication of outputs configured within the network database.

The 24 input 24 output Supernode II® is at the heart of the electrical system. With its dual CAN feature, integration with any chassis J1939 network is a snap. Expanded utility functions, versatile flash pattern capabilities, and almost unlimited timers and counters give you everything you need to get the job done.

The UltraView 700 is a CAN based display with a fully modular design and numerous opportunities for customization.



Why J1939?

CAN (Controller Area Network) is used as an embedded network and as an in-vehicle power-train network in many on and off highway vehicles. In 1998, the SAE published the J1939 Message Protocol for use on CAN bus systems. The J1939 specifications with its engine, transmission and ABS brake message definitions is the industry standard for diesel engine applications. Being able to interface the chassis and body electrical systems with the components of the power-train makes J1939 the logical choice for physical layer and communication protocols.

Power Distribution Modules have built in circuit breaker protection, eliminating the need for discrete components.

Ultraview displays come in two sizes and allows true multi-station control.

Achieve multiple flash patterns with the built in flash capacity of the Supernode II and High Power Distribution Modules. Program flash patterns to change at set intervals to give the appearance of random patterns.

Supernode II

Features

- Consolidates functions of ES-Key modules - USM, Data Logger, Digital input Module and Power Distribution
- Module for a reduced node count and simplified operation
- SAE J1939 CAN engine message reception and ES-Key I/O associations
- 24 inputs/24 outputs (18 positive @ 13 amps and 6 negative @ 2 amps)
- Integrated USM and Data Logger
- Diagnostic indicators for all I/O
- Built in USB port
- Models with built-in modems available
- Integral power connectors
- Environmentally sealed -IP67
- Backwards compatible with original Supernode
- Real time OS with ARM processor
- Flashers at .25 second intervals
- Optional wireless connectivity

Supernode II	
Part No.	Modem
119890	No
119891	Yes



USB port for digital transfer and diagnostics



Integral power connectors for Duetsch and other connectors



Input and Output LED status indicators

The UltraView 700 is a CAN based display with a fully modular design and numerous opportunities for customization.

UltraView allows operators to access critical functions easily. Displays can be programmed so that your most critical functions can be accessed from any screen at any time. No matter where you are in the menu, your home screen is a single button press away. In the event something is out of normal operating parameters, warning messages quickly alert the operator. Coupled with the Class 1 ES-Key system, UltraView displays have unparalleled diagnostic capability. Engine and electrical system diagnostics are easily accessed. With available service reminders, potential problems can be prevented.

Features

- J1939 CAN Based Display (2 ports UV700)
- Fully compatible with current and legacy ES-Key systems
- Easily retrofitted on existing ES-Key systems
- Bonded LCD screen viewable in direct sunlight
- Fully configurable by the OEM
- Available with multiple language options
- Flexible mounting options: Flush mount, rear mount or pedestal mount
- Totally sealed display (IP-67 front and rear) suitable for mounting anywhere on the apparatus
- Certified for operation in extreme conditions with operating temperature range -40° to +85° C

Specifications

- Display: 7"/178mm color transmissive TFT LCD
- Resolution: WVGA 800 x 480 pixels, 16 bit color
- Landscape or portrait orientation
- NTSC/PAL video input
- Industry standard Deutsch connectors
- 3 configurable analog inputs
- 1 digital output 500mA
- 8-35 VDC operating voltage



UltraView displays can be programmed to display a wide variety of vehicle functions such as climate control.



Optional touch screen display provides both screen and actual switch control for an intuitive and functional display layout.



UltraView uses LCD bonded technology for the most visible display even in direct sunlight. Screen can be adjusted for night vision also.



When used in fire apparatus, UltraView can monitor the aerial controls making aerial operations much easier.



Programmable screens for trouble shooting and diagnostics.



Also used in fire apparatus for pump panel information.



Input and output use is easily accessed.



Engine data is always available at the touch of a button.

The UltraView 450 is a CAN based display with a fully modular design and numerous opportunities for customization.

UltraView provides real time information and intuitive controls that allows the user to have more information and control than ever before. Fully customizable with available touch screens, UltraView displays can have both on screen and actual switch control providing an intuitive and functional display layout.



Features

- J1939 CAN Based Display (2 ports)
- Fully compatible with current and legacy ES-Key systems
- Easily retrofitted on existing ES-Key systems
- Bonded LCD screen viewable in direct sunlight
- Fully configurable by the OEM
- Totally sealed display (IP-67 front and rear) suitable for mounting anywhere on the apparatus
- Certified for operation in extreme conditions with operating temperature range -40° to +85° C
- Available with multiple language options
- Flexible mounting options: Flush mount, rear mount or pedestal mount

UltraView 450

- Display: 4.3" color transmissive TFT LCD
- Resolution: WVGA 480 x 272 pixels, 16 bit color
- Landscape or portrait orientation
- NTSC/PAL video input
- Industry standard Deutsch connectors
- 1 configurable analog input
- 1 digital output 500mA
- 6-32 VDC operating voltage (24V system compatible)

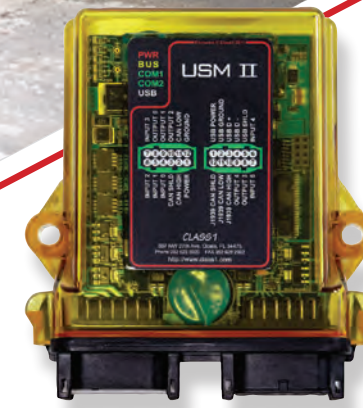

USM II

Universal System Manager USM & USM II

- 4 polarity selectable inputs
- 3 outputs, .25 amps each
- Advanced Load Manager
- Real time diagnostics



USM



Supernode II

- Built in USB port
- Integral power connectors
- New sealed packaging
- Backwards compatible with original Supernode
- Real time OS with ARM processor
- Flashers at .25 second intervals
- Optional wireless connectivity

The 1Touch switch panel is a fully customizable switch solution for use with the ES-Key distributed multiplex network. The 1Touch switch allows control and indication of outputs configured within the network database. The 1Touch switch panel is available in four layouts: 4 switches (2 pairs, p/n 120881), 8 switches (4 pairs, p/n 120882), 12 switches (6 pairs, p/n 120883), and 16 switches (8 pairs, p/n 120884).

Features

- Backlit switches with customizable transparent colored switch caps (clear, blue, red, yellow, amber, and green)
- Customizable switch labels protected by the switch caps
- Dimmable backlighting
- Individual control over backlights
- Configurable switches with 6 different switch functions (momentary, bi-stable, dimmer, and 3 toggle types)
- Two state indicator LEDs (green and yellow) per switch
- ES-Key network and peer-to-peer compatible
- 12 and 24 volt compatible
- Sealed to IP67



1Touch 8 Switch Panel with colored switch caps



1Touch 16 Switch Panel



1Touch 4 Switch Panel



1Touch Colored Switch caps available in six colors

1Touch™ Switch Panels

1200-04-00-CL1.....	4 Switch Positions
1200-08-00-CL1.....	8 Switch Positions
1200-12-00-CL1.....	12 Switch Positions
1200-16-00-CL1.....	16 Switch Positions
120723.....	Switch Cap, Clear
121306.....	Switch Cap, Clear, Textured
120723-01.....	Switch Cap, Red
121306-01.....	Switch Cap, Red, Textured
120723-05.....	Switch Cap, Blue
121306-05.....	Switch Cap, Blue, Textured
120723-03.....	Switch Cap, Yellow
121306-03.....	Switch Cap, Yellow, Textured
120723-04.....	Switch Cap, Green
121306-04.....	Switch Cap, Green, Textured
120723-02.....	Switch Cap, Amber
121306-02.....	Switch Cap, Amber, Textured



Switch Input Module

- Available in 2 configurations:
 - 16 polarity selectable inputs
 - 16 polarity selectable inputs with 3 polarity selectable .25 amp outputs



Switch Input Module

Analog Input Module

- For custom applications
- Available in 0-5VDC, 0-30VDC, 4-20mA resistive and temperature



Analog Input Module

Pump Sensor Module

- 3 - 0 to 5 Volt analog inputs
- 2 frequency inputs
- 1 resistive input
- Sealed to IP67
- Industry standard enclosure

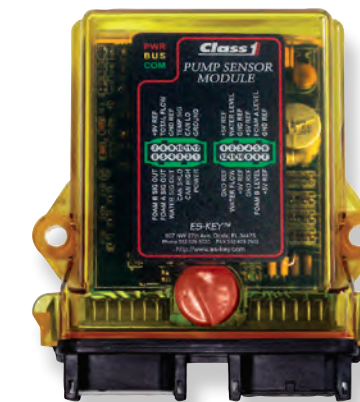

Pump Sensor Module

High Density Power Distribution Modules

- Robust CANNON connector for high current power input
- Deutsch connectors for inputs, outputs, and CAN bus
- Integrated switch panel to enter device configurations (i.e. module address, polarity inputs)
- 7-segment display and diagnostic indicators for visual feedback
- Sealed to IP 67
- 21 solid state outputs with a combined maximum of 200A:
 - 1 ground, 2A
 - 20 positive, 13A (4 with PWM control)
- 10 selectable polarity (positive or ground) digital inputs
- 12V and 24V compatible



High Density Power Distribution Module

Solid State Power Distribution Modules

- Built in circuit protection
- Built in flashers
- PWM capable
- Available in several I/O configurations
- 8 outputs @ 7.5 amps
- 8 outputs @ 10 amps with 8 polarity selectable inputs
- 6 outputs @ 7.5 amps with 2 polarity selectable inputs
- 4 outputs @ 7.5 amps with 4 polarity selectable inputs
- 4 outputs @ 7.5 amps with 4 ground outputs @ .25 amps each

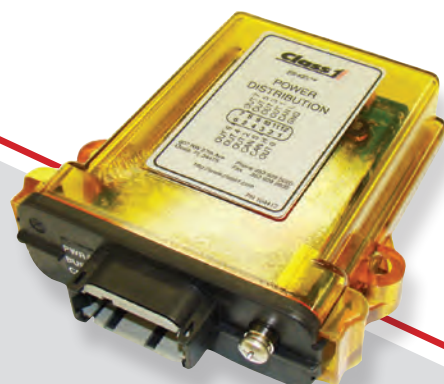

Power Distribution Module

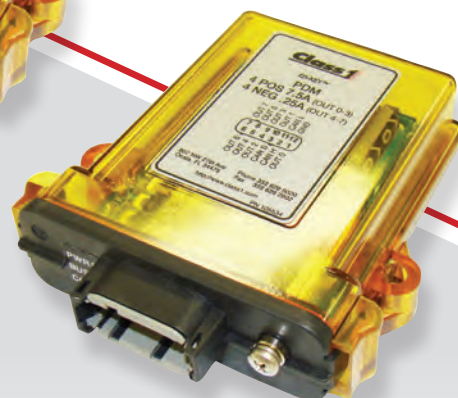

Power Distribution Module 4out/4in

Electro-Mechanical Power Distribution Modules

- 12 relay outputs @ 30 amps with 8 polarity selectable inputs

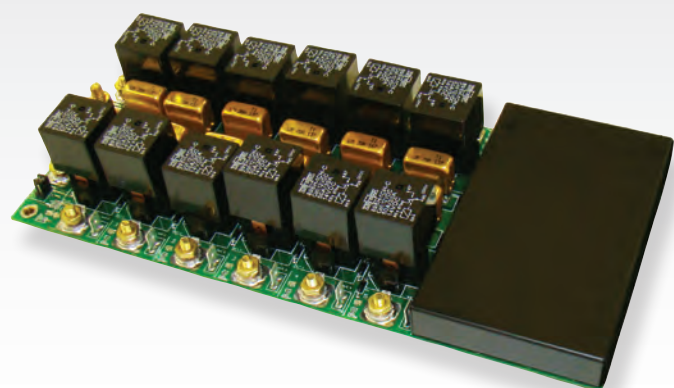

Electro-Mechanical Power Distribution Module

Information Center

- Quickly provides operator with important information
- Programmable greeting screen
- 50 pages of text information
- On board diagnostic gateway to the ES-Key system

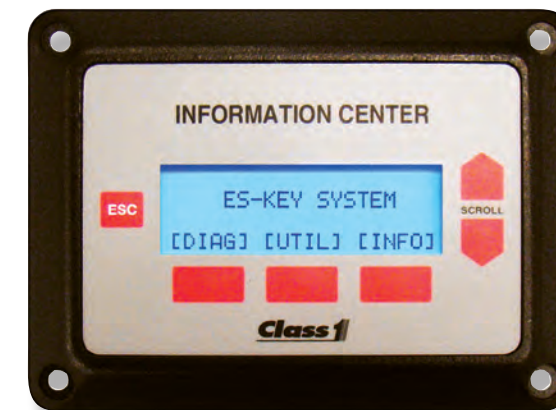

Information Center

Data Transfer Dongle

- Allows transfer of ES-Key data bases to the vehicle without connecting the PC



Data Transfer Dongle

USB to CAN & Serial to CAN Interface Modules

- Converts USB or Serial Information to CAN for PC to ES-Key Communication



USB to CAN Interface Module

Modem Module

- Remote diagnostics via analog phone line
- Integral serial to CAN interface
- Complete remote diagnostic and programming capability



Modem Module





Climate Control Module

- Multi station control over CAN
- Two temperature inputs
- Air conditioner clutch and heater valve control
- Smooth PWM blower fan output
- Automatic or manual mode

Seat Belt Warning

- Input module with two 12 pin connectors
- Visual display module
- Advanced Load Manager Module provides for up to 10 seat and 10 belt inputs

Vehicle Data Recorder

- Deutsch Box with a single 12 pin connector
- Three terminals for Powertrain CAN for engine RMP, Throttle percentage, vehicle speed, ABS events and transmission range information
- Three terminals for Seatbelt CAN (seat and seat belt status)
- VDR module has two inputs, one power and one ground (Master warning and park break)
- Two outputs of opposite polarity (Seatbelt/System warnings) are also available

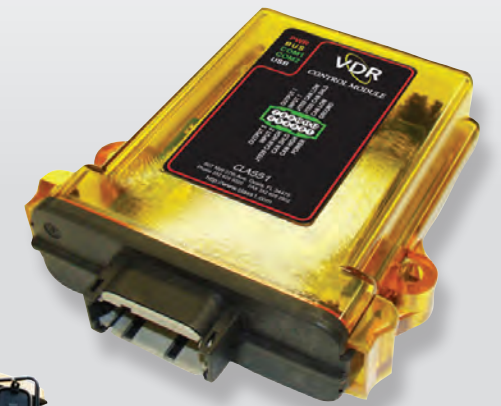

Joystick Interface Module and Proportional Valve Driver Module

- Joystick, Toggle Switch or Network Control
- Joystick learn mode
- 8 Channel 16 function proportional control
- 2 fully programmable profiles per channel including:
 - Minimum and Maximum PWM
 - Dead band
 - Ramp On
 - Ramp Off
 - Frequency

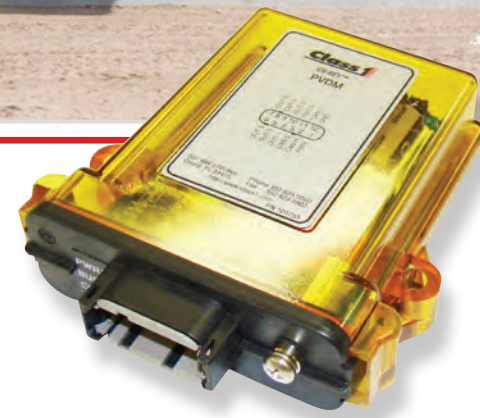

Proportional Valve Driver Module



Joystick Interface Module



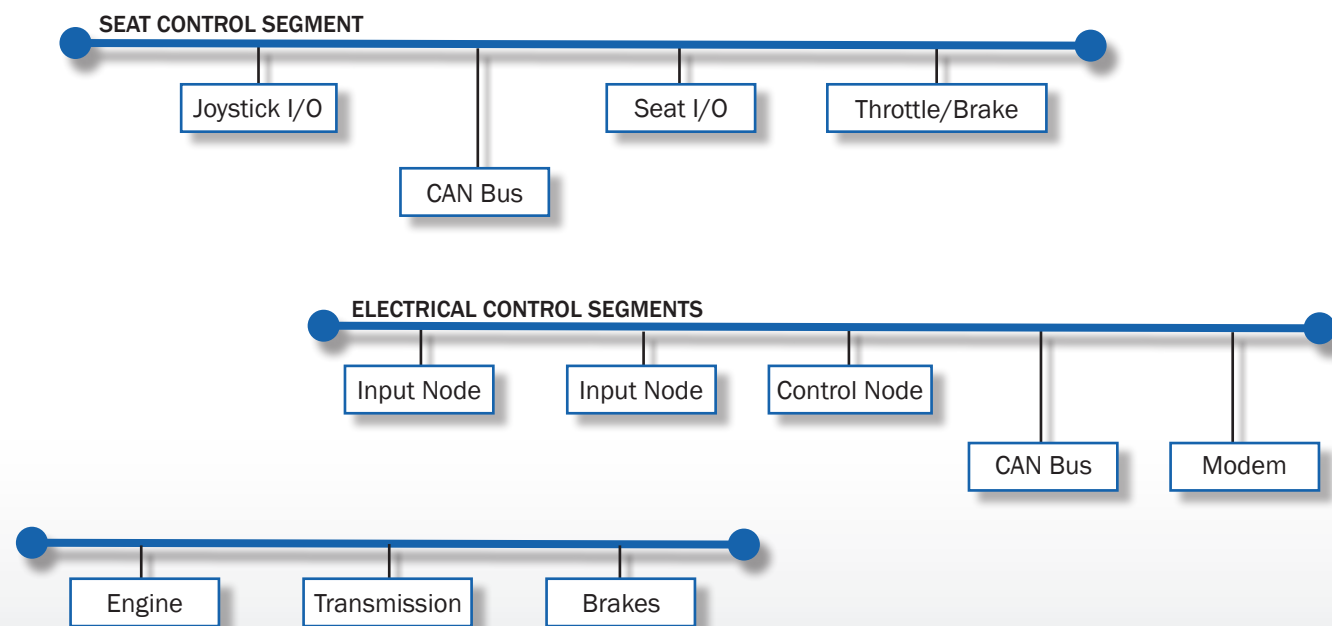

The new TITAN railcar mover has demanding control requirements. The machine operates as a mobile railcar mover switching and spotting railcars for in-plant industrial applications such as chemical plants, process industries, grain elevators, etc. The ES-Key system ties all of the components together to provide a total network solution.

TRACKMOBILE MaxTran/MaxTrac Controller

- Anti-Wheel slip - prevents the wheels from free-spinning during acceleration by communicating slip conditions to the throttle module which adjusts engine torque request.
- Anti-Lock braking — prevents the wheels from “locking up” during hard braking through dynamic brake pressure adjustments.
- Automatic weight transfer — maximizes traction by transferring thousands of pounds of weight from the railcar to the wheels for the TrackMobile.

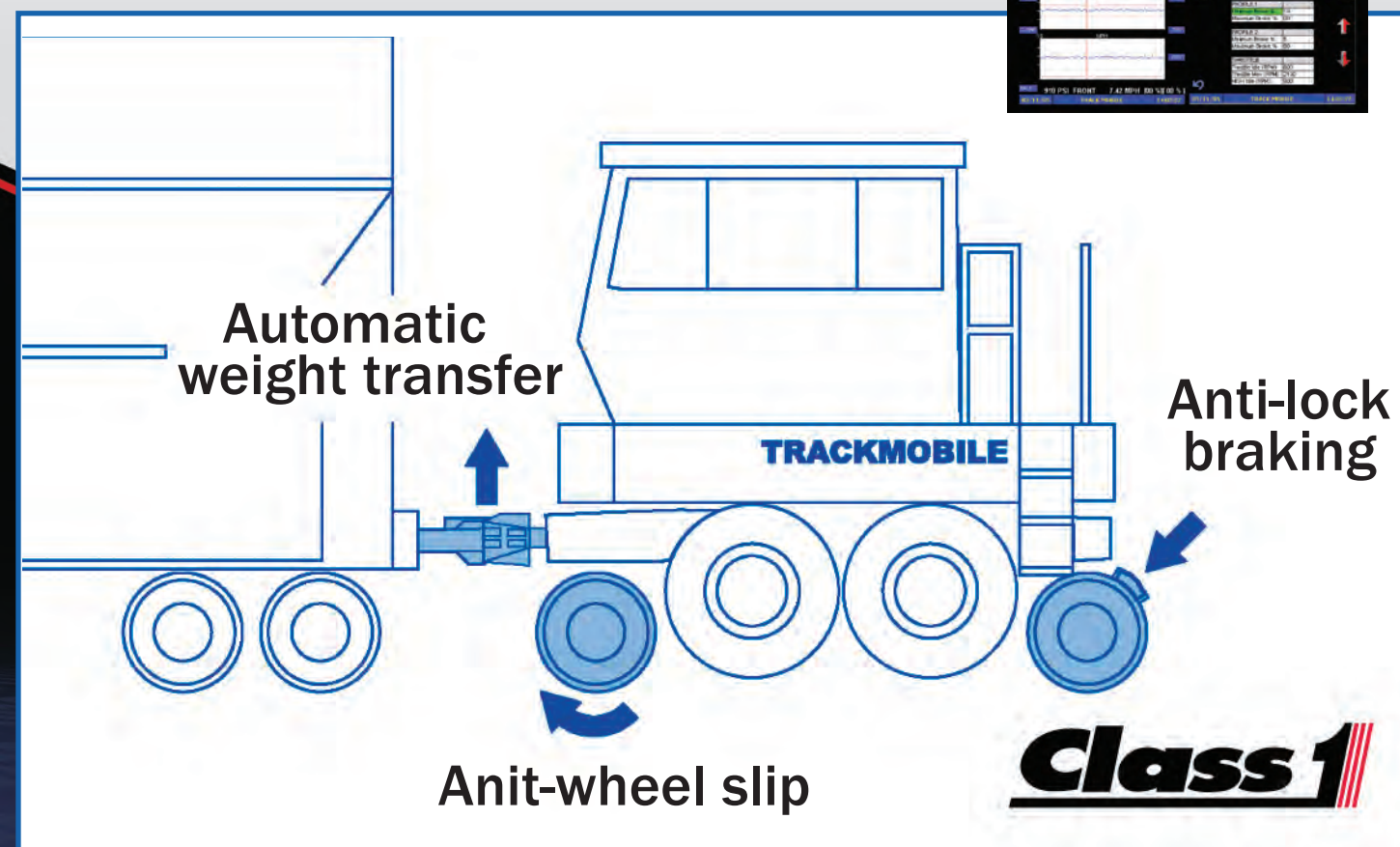

ES-Key Service Software

With the ES-Key Professional software... you're in control.

Configuration made easy. The ES-Key Professional software provides you with a quick and easy way of programming your vehicle. An extensive report feature documents your system as you program. Logic as simple or as complex as necessary to accomplish your goal. You control the program so you're in charge. Wire your vehicles the same and change their behavior by simply changing the program. Activate options, change flash patterns and load management setting without changing a single wire.

Configuration

- Name your own circuits
- Use simple logic statements
- Unlimited load management
- Nest logic to perform any interlock
- Use virtual circuits to create custom program functions
- Automatically create printable system reports
- Configure display messages

Diagnostics

- Real-time feedback
- Detailed CAN information
- Fault code reporting
- Module status information
- Local or dial up connection capability
- Easy down load capability
- Force on or force off any input or output
- View component firmware versions

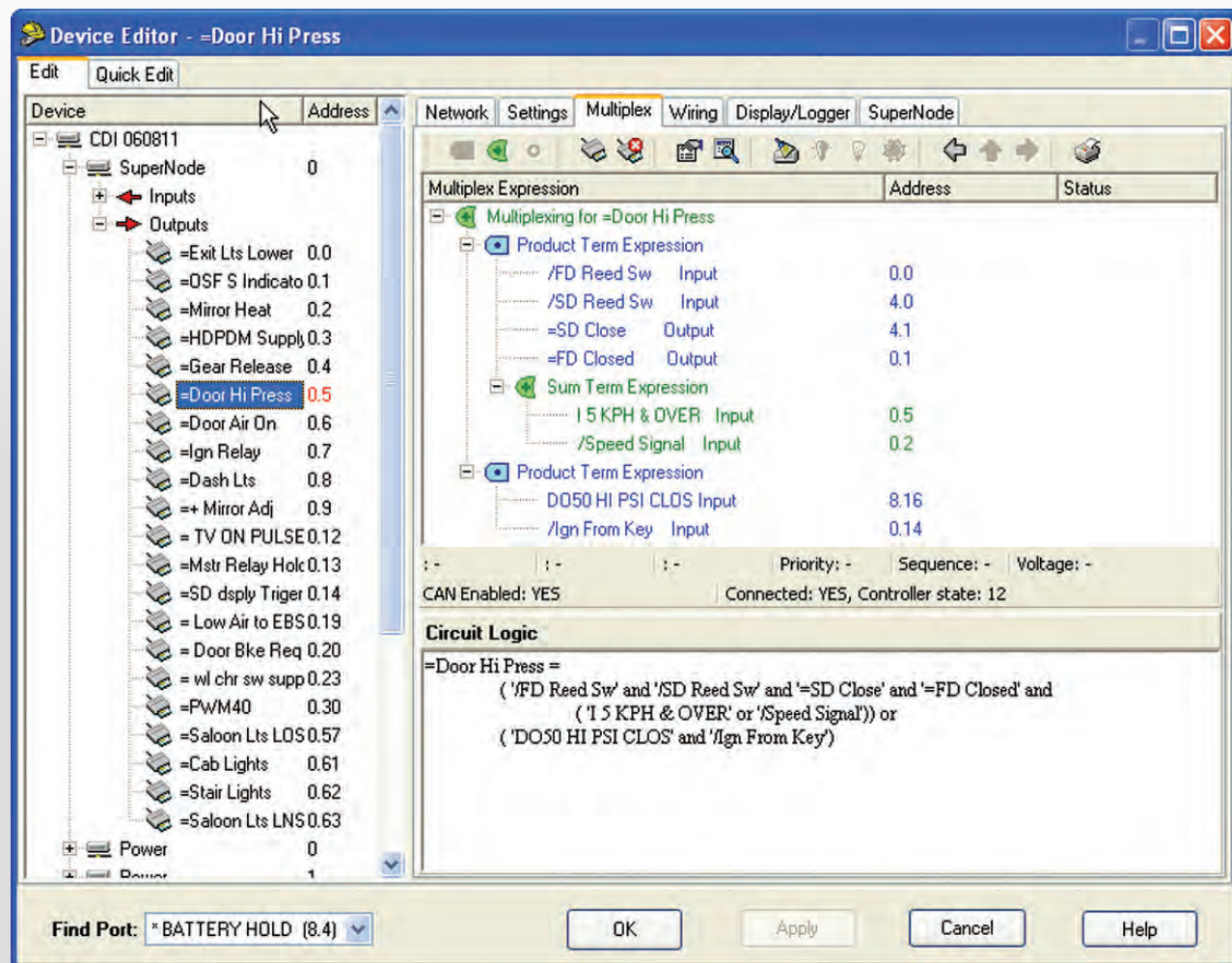

Diagnostics and troubleshooting are easy with the ES-Key Pro Service software. Connect to your vehicle locally or via a dial up telephone line. Download the vehicles program and you're in. Troubleshoot the entire system or one single output. With the ability to force on or off any input or output, you can diagnose problems quickly and easily. Downloading and printing reports and data logger information is effortless. Finding and fixing electrical system faults has never been easier.

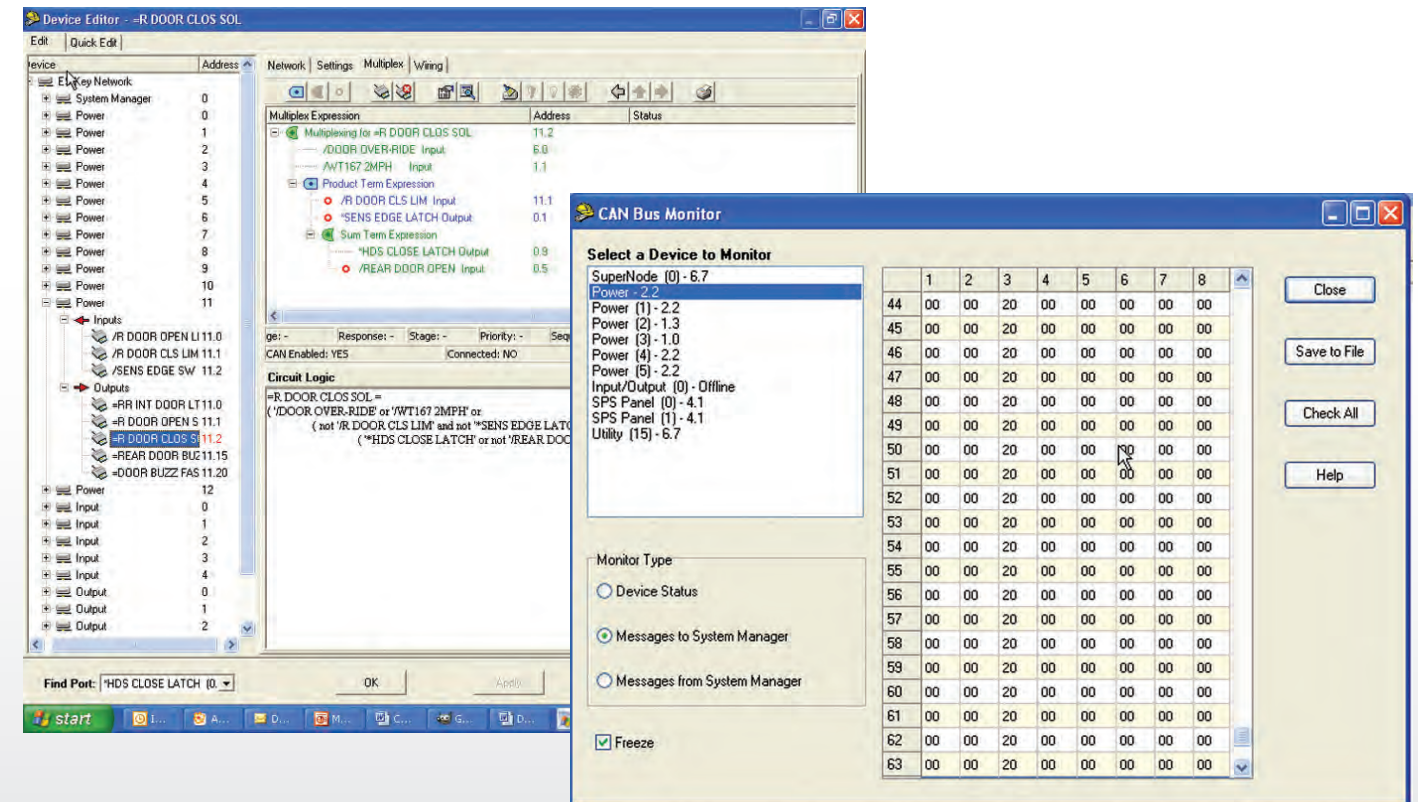

With the ES-Key QR code, you're always up to date with our current specifications.

Simply download the appropriate word files, then type cut and paste into your specs when placing your order. We keep our website up to date, so you will be too.



www.es-key.com



WWW.ES-KEY.COM



Class 1[®]

607 NW 27th Avenue • Ocala, FL 34475
Phone: 352.629.5020 • Fax: 352.629.2902 • 800.533.3569
WWW.CLASS1.COM

Copyright 2012, Class 1, Rev 1, 4/2012

Note: Hale Products Inc./Class 1 cannot assume responsibility for product failure resulting from improper maintenance or operation. Hale Products Inc./Class 1 is responsible only to the limits stated in the product warranty. Product information contained in this material is subject to change without notice.